

**VA**RIABLE **S**PEED **CO**NTROLLER

# VARIABLE SPEED CONTROLLER FOR PUMPS



**NASTE<sup>C</sup>**  
> we move it faster >

# VASCO - VArIable Speed COntroller

is a purpose-built family of variable frequency drives, designed to control and protect pumping systems based on changing pump speed.

From water supply for domestic, irrigation, commercial and industrial applications, to heating and air conditioning, from filtering to pressure washing, the VASCO - VArIable Speed COntroller range perfectly fits any new or existing application ensuring:

- energy and cost saving
- simplified installation
- longevity of pumping system
- greater reliability

## MAXIMUM STURDINESS AND COMPACTNESS

VASCO - VArIable Speed COntroller units are extremely compact and, connected to any pump on the market, will manage the operation of the pump to maintain a constant desired physical dimension (such as pressure, flow, temperature or other). The pumping system runs only at the speed necessary to meet the user's requirements, ensuring energy savings and extending the life of the system.

The device also provides motor protection and monitoring, such as:

- protection against overload and dry running
- indication of input current and supply voltage
- integrated soft start and soft stop functions, extending the life of the system and reducing peak absorption

- recording running hours and loggings errors and alarms reported by the system
- controlling a second or third pump at constant speed DOL (DOL: Direct On Line)
- connect to other devices to get combined operation

The all-aluminum structure provides the device with extreme solidity and easy cooling. The high level of protection allows for the installation of the device in humid and dusty environments.

## NEW KEYBOARD

- OLED graphic display with extended operating temperature range and wide viewing angle.
- Digital text rotation based on installation position.
- LED indication for standby, run and alarm conditions.
- Audible alert in case of alarm.

## ROTATING COVER

The cover and keyboard can be freely rotated in relation to the base according to installation and wiring needs.

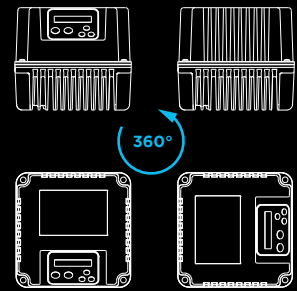

## The installation is simple and intuitive, requiring just a few quick steps:

- Power connection.
- Connection to the pump.
- Connection to the sensor, located wherever in the piping you want to maintain the desired constant physical dimension (pressure, flow, liquid temperature, etc.).
- Set device to configure the pump to the system and the desired performance.

Upon the initial startup of the device, you directly access the guided initial configuration process via the keyboard or app, allowing for a quick yet comprehensive programming of the inverter.

Additional parameters can then be configured based on three levels of access:

- **End user level.** The only level which can be accessed without a password. It allows the user to monitor electrical and hydraulic parameters and the status of the inverter and pump.
- **Installer level.** In this level the installer can configure the pump system to the characteristics of the hydraulic system. A password is required.
- **Advanced level.** This level allows the electrical configuration of the inverter according to the pump. Another password is required.



# IT CAN BE INSTALLED DIRECTLY ON THE MOTOR OR DIRECTLY TO THE WALL WITH A SUPPLIED INSTALLATION KIT

## MOTOR KIT

The inverter is cooled by the motor cooling fan. Motor kit consists of 4 special clamps (or flange adapter) to secure the device to the motor fan cover (or motor feet).

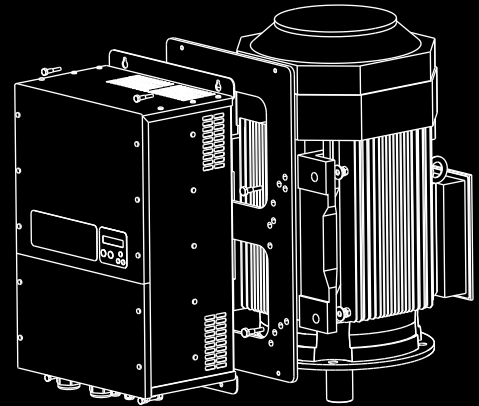
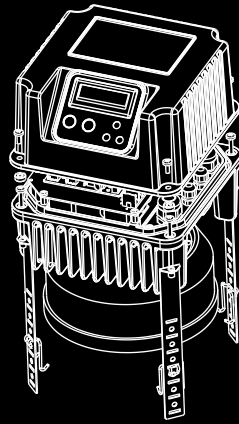

## NEW MOTOR FASTENING HOOKS

The fastening hooks on the motor fan cover have been completely redesigned to be perfectly compatible with the majority of motor types.

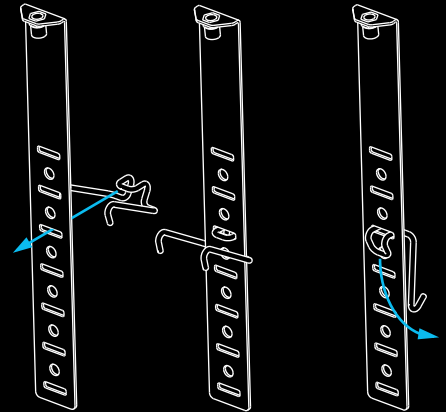

## WALL KIT

The unit is cooled by an external cooling fan attached to the inverter radiator. A special metal bracket is supplied for device to be mounted on the wall.

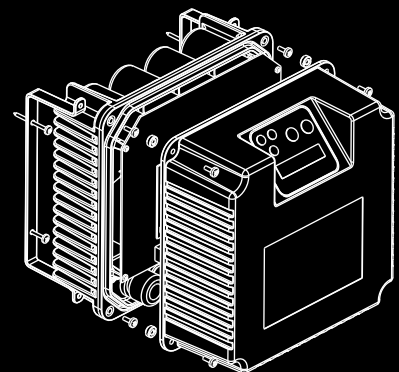
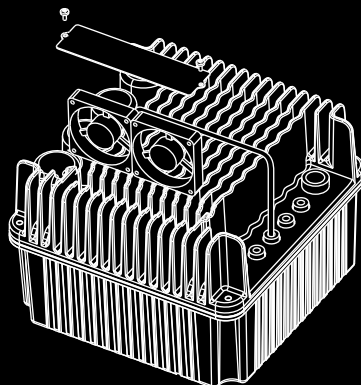

## UNIVERSAL CONTROL

The various models comprising the range differ from each other in terms of size and power electronics, while the control board, keyboard, and firmware remain the same.

In this way, once you have learned how to use and program one model, installing the other models becomes simple and immediate, regardless of their power.

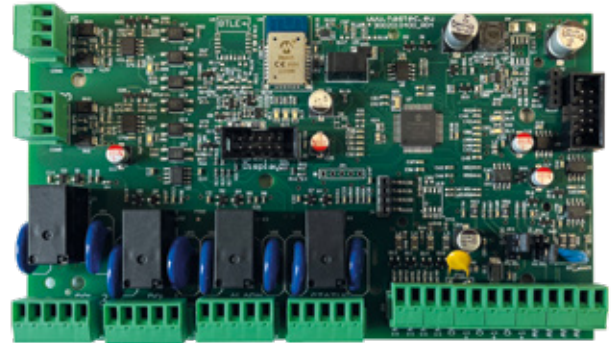

## DESIGNED TO LAST

The technological solutions adopted in electronic and mechanical design are the result of extensive experience gained over the years with thousands of devices in various application areas.

To ensure greater durability and performance even at high temperatures, the three-phase models are equipped with a DC BUS with film capacitors. All of this is aimed at providing an expected lifespan exceeding 10 years.



## CONSTANTLY UPDATED FIRMWARE

To obtain the latest available firmware version, updated with new features and improvements, simply connect to the device via smartphone and follow the guided update process provided by the app.

This ensures that each installation is carried out with the utmost capabilities, and it allows the addition of new functions to existing systems.



# EFFICIENCY AT MAXIMUM LEVELS

The use of state-of-the-art power electronic components and the adoption of film capacitors allow the achievement of maximum levels of efficiency, both in terms of electrical consumption and harmonic mitigation. In fact, all models belong to the efficiency class IE2 according to the EN61800-9-2 standard.



# AUTOMATIC ADAPTATION

In addition to protecting the motor from overvoltages and overloads, the inverter is capable of automatically adapting its performance to power and environmental conditions.

This means that if the ambient temperature or the current absorbed by the motor were to reach the allowed limits, the inverter will automatically limit the motor frequency, ensuring the continuity of operation.

Software implemented in each drive of VASCO - VArIable Speed COntroller range is the result of a long-time experience in solving customer requests and constantly following new drive applications.

### MINIMUM MOTOR FREQUENCY

This parameter prevents motor operation below a certain frequency, thus avoiding damage to the thrust bearing of the submersible motors.

### MINIMUM MOTOR FREQUENCY RAMP

Motor can accelerate from 0 to the minimum motor frequency following a very fast ramp and then go through a slower ramp.

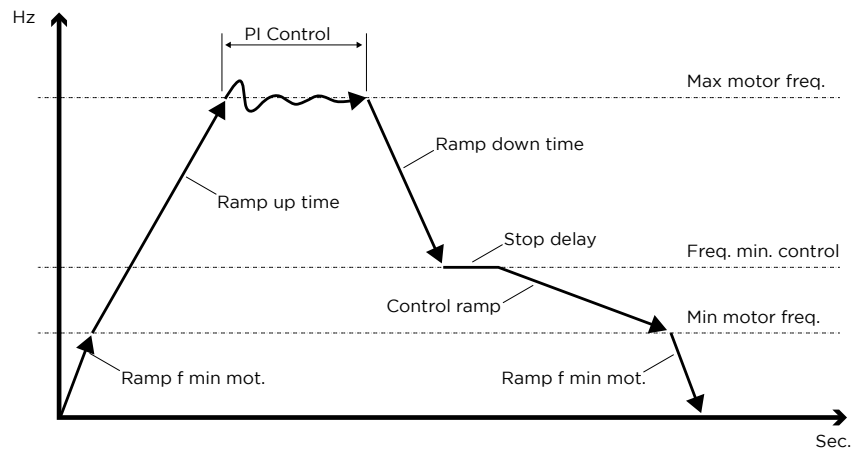

### INTELLIGENT STOP OF PUMP AT NO FLOW CONDITION

Below minimum control frequency, the inverter gradually reduces the pump speed while monitoring the pressure transducer signal. If this value is maintained close to the set pressure, the inverter will reduce the output frequency until stopping the pump definitely.

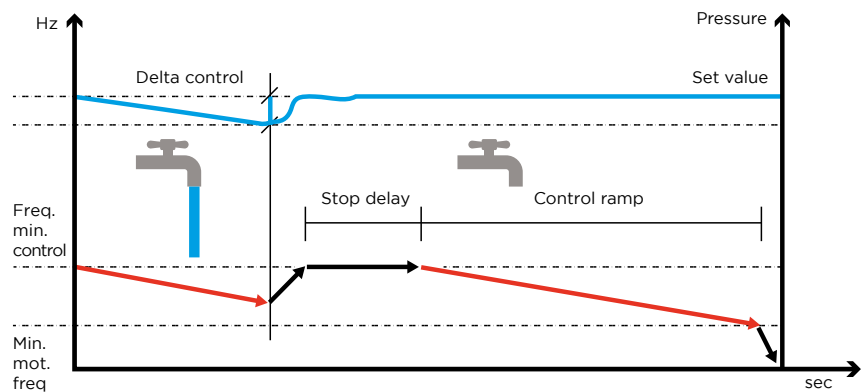

### MAXIMUM AND MINIMUM ALARM PRESSURE

When the pressure rises above a certain settable pressure value, the inverter will stop the pump to prevent damage to the hydraulic components in the system. Similarly, if the pressure drops below a certain pressure an alarm is triggered and the pump is stopped.

## LOSS COMPENSATION PROPORTIONAL TO THE WATER FLOW

If the pressure sensor is placed near the pump, with the increase in flow the pressure value at the furthest outlet is lower than the set pressure.

It is possible to vary the set pressure in proportion to the frequency to compensate pressure loss in the pipes.

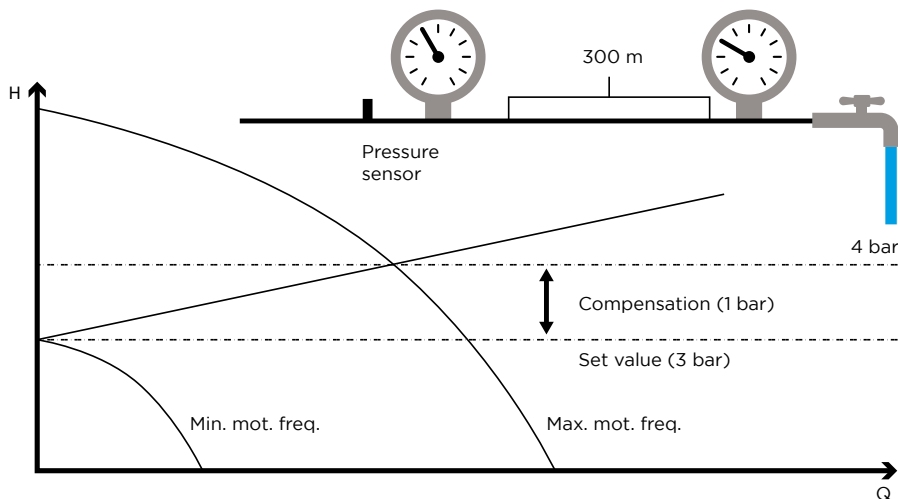

## DRY RUN ALARM THROUGH ELECTRICAL PARAMETER READING.

When the pump operates in a dry run condition, the power factor value ( $\cos\phi$ ) or the current absorbed by the motor falls below a configurable critical value, and the inverter stops it. The device then performs several restart attempts, which are customizable. If the water shortage alarm is not resolved at the end of these attempts, the pump is permanently stopped.

## V/F PROGRAMMABLE CURVE

Device offers two different methods of torque control (voltage) versus pump speed (frequency):

- constant torque (linear V/f)
- quadratic variable torque (squared V/f)

For centrifugal pumps, energy savings can be obtained by selecting squared V/f control.

## SELECTABLE SWITCHING FREQUENCY

In the presence of long cables, as in the case where the device powers submersible pumps, it is important to decrease the switching frequency to reduce electrical stress on the motor winding. Lower switching frequencies also help in reducing the inverter's overheating in particularly hot working environments.

### PERIODIC START ANTI-BLOCKING

To prevent the blocking of mechanical and hydraulic parts of the pumping system, it is possible to set the periodic start of the motor after a certain period of inactivity.

### PIPE FILLING RAMP

When the hydraulic system is empty, starting the pump, even under pressure control, could cause water hammer effects and damage the pipes. To prevent this, the “filling ramp” parameter is available, allowing the user to extend the pump’s startup ramp until the pipes are completely filled.

### DYNAMIC PARAMETER CONFIGURATION

Changing certain parameters often requires the adjustment of others to ensure the proper functioning of the system. However, it is not always easy to know or remember the existing relationships between all parameters. For this purpose, the device is capable of automatically adjusting secondary parameters based on primary parameters, preventing users from overlooking important details.

### CONFIGURABLE ANALOG AND DIGITAL INPUTS

Analog and digital inputs are extensively configurable based on user needs, allowing for versatility to meet the requirements of a wide range of applications.

### DIFFERENTIATED MANAGEMENT OF ALARMS AND WARNINGS

In addition to alarms, which result in motor shutdown, the device notifies the user of possible malfunctions and, where possible and if desired, implements automatic corrections to motor control to prevent system downtime. Both alarms and warnings are stored in the device’s history for easy reference over time.

### REMOTE CONTROL VIA WIFI OR GSM

In addition to Bluetooth connectivity for control through a smartphone and app, it is possible to install a Wifi or GSM card onboard the device and manage the system remotely through the **remo.nastec.eu** portal. Therefore, there is no need to install any external communication device or subscribe to expensive telemetry services.

### AUXILIARY CONTROL MODE

In some cases, it is necessary to switch from the main control mode (e.g., constant pressure) to the auxiliary mode (e.g., fixed frequency). In such cases, it is sufficient to program the desired auxiliary control mode and act on the dedicated digital input.



### ADVANCED MOTOR CONTROLS:

- Field Oriented Control (FOC) with motor autotuning.
- Control of next-generation asynchronous motors, both three-phase and single-phase.
- Sensorless control of permanent magnet synchronous motors.

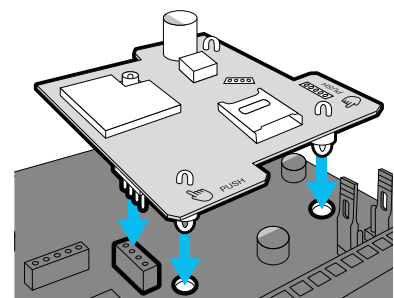

## PREDICTIVE ANALYSIS AND REMOTE CONTROL

Through predictive analysis performed by the device during operation, it is possible to intervene before a problem occurs, minimizing intervention and repair costs.

If the device is connected to the Internet, warning or alarm notifications can be sent via email to the concerned users. For this purpose, a quick configuration from the **remo.nastec.eu** portal is sufficient.



## MODBUS RTU AND BACNET CONNECTIVITY AS STANDARD

The device can be connected via the RS485 serial port to external control systems using the MODBUS RTU and BACnet protocols.



## ADDITIONAL FEATURES UPON REQUEST

If the application requirements are not met by the standard functionalities, Nastec can offer the implementation of additional features according to customer specifications.

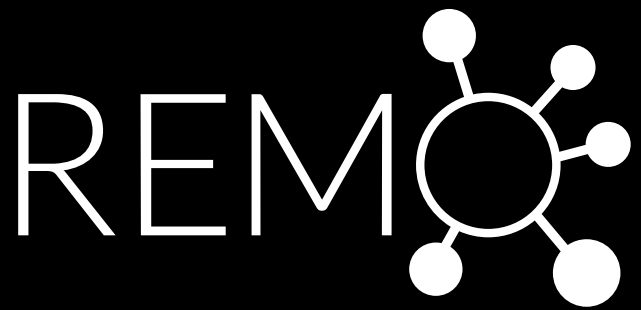

[remo.nastec.eu](http://remo.nastec.eu)

## REMO, the revolutionary Nastec system for remote controlling devices.

To implement the REMO control system you will need to:

- Install an Android or iOS smartphone nearby Nastec device you wish to control. The smartphone, connected to the network via Wifi or GSM, communicates via Bluetooth with the associated Nastec device.
- Download and install Nastec NOW App on the smartphone, register for free and activate REMO mode on the App.
- From a PC or mobile, access to **remo.nastec.eu** to monitor or program the Nastec device from anywhere in the world.

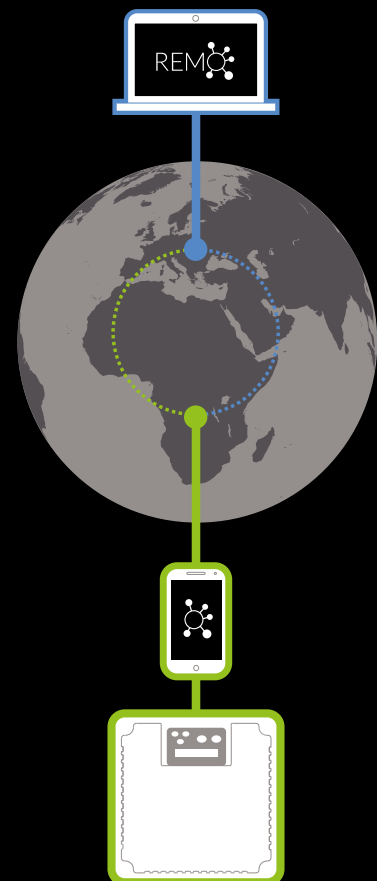

In addition to constant pressure control, VASCO - VARIable Speed COntroller allows other control modes such as fixed frequency, constant flow, constant temperature.

**CONSTANT PRESSURE**

The inverter controls the pump speed to maintain constant pressure at a set point independent of the water demand in the system.

In a hydraulic system equipped with inverter, the standard pressure tank is replaced by a smaller tank which functions to maintain the set pressure in the system when the pump is stopped.

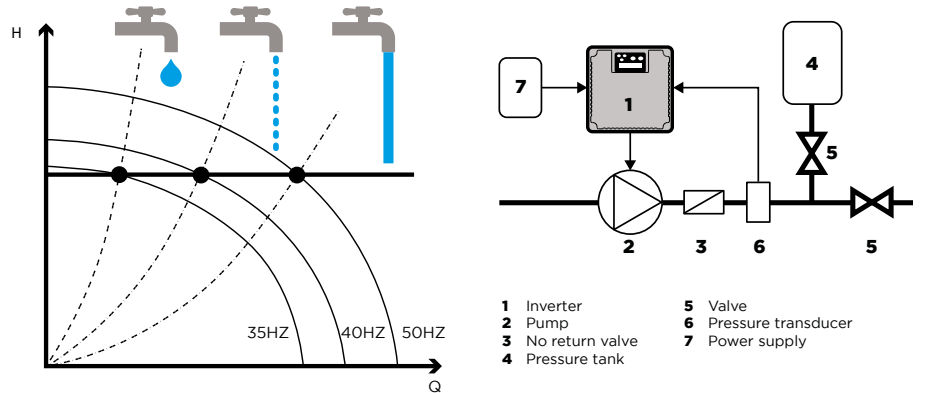

**INTERNAL OR EXTERNAL SETTING**

The pressure setpoint can be configured either through the keypad or provided externally through a 0-10 V or 4-20 mA signal.

**CONSTANT PRESSURE 2 VALUES**

By selecting the constant pressure 2 values control mode, in irrigation systems, only one pump can serve two zones with different pressure sets. It is possible to switch the two values by acting on a digit input contact.

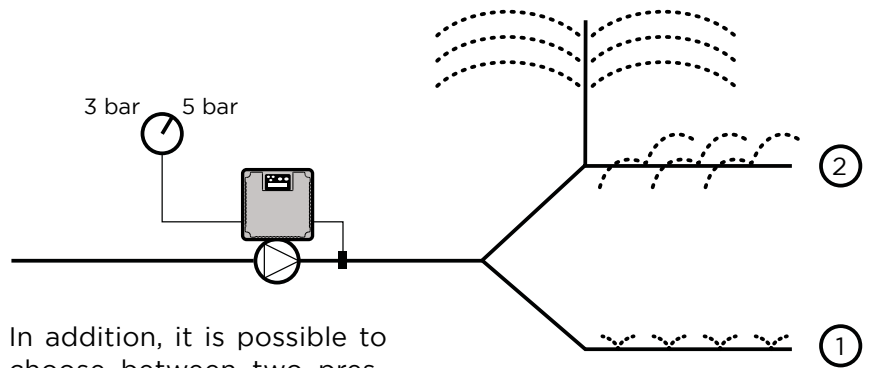

In addition, it is possible to choose between two pressure sensors located at different points in the hydraulic circuit.

**FIXED FREQUENCY 2 VALUES**

If it is not necessary to operate at constant pressure but is required to select 2 different pump speeds, by selecting fixed frequency 2 values control mode it is possible to switch the 2 values by acting on a digit input contact.

### CONSTANT TEMPERATURE

The control method at constant temperature is used to maintain the temperature of the pumped fluid to vary the thermal load.

This control system is used in air conditioning or refrigeration and cooling towers. In this latter case, for example, the temperature measured by a sensor in the return water is kept constant.

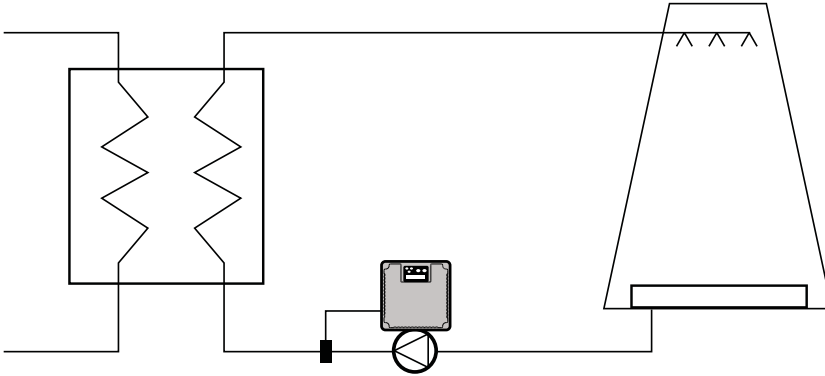

### CONSTANT FLOW

By selecting the constant flow control mode and using a flow transducer, it is possible to control the flow of the pumped liquid to vary the system condition. This control mode is used, for example, in a system for

filtering the pumped fluid in which the obstruction of the filter would lead to a progressive reduction of the flow rate if it is not compensated by an increasing of the pump speed.

### CONSTANT LEVEL

When it is desired to maintain the level in a tank or well at a constant value, it is sufficient to install a level sensor and configure its full scale appropriately.

The inverter automatically increases the pump's rotational speed as the water flow into the tank increases.

### EXTERNAL FREQUENCY

In some application, it is chosen to change the frequency of the pump by using an external signal coming from a trimmer or a PLC. In this case, after selecting the External Frequency control mode, it is enough to connect an input signal 4-20 mA or 0-10V, proportional to the desired frequency, to the AN4 analogue contact.

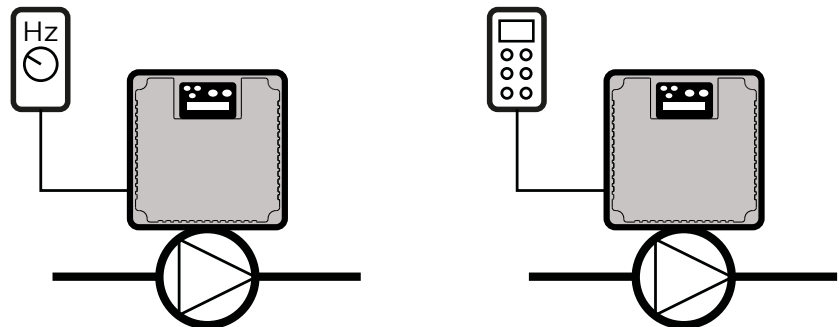

# With VASCO - VArIable Speed COntroller inverters is possible to realise booster sets with one or more pumps (up to 8) to be controlled at constant pressure.

The devices can be mounted directly on the motor fan cover using a specific mounting kit.

The robust attachment system allows installation even on horizontally oriented pumps. The display can be digitally rotated.

Mounting on the motor ensures not only compactness and savings in wiring and the electrical panel but also excellent cooling of the inverter and low electromagnetic emissions due to the short motor cable lengths. The high degree of protection allows installation even in humid and dusty environments.

If it is not possible to install the device directly on the motor fan cover, a wall mounting kit is available, consisting of a cooling fan powered by the device itself and stainless steel wall brackets. By placing the inverter in an additional panel, the unit can be installed in the immediate vicinity of the pump.

The COMBO mode allows alternating the start of the pumps based on the actual operating hours of each pump in the group. In case of a malfunction or alarm in any unit of the group, the remaining pumps continue to operate to ensure continuous service.

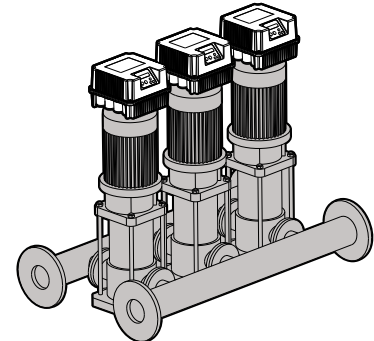

After replacing the damaged unit (pump or inverter), the COMBO wear leveling system shifts the workload more to the new pump.



## **CASCADE OR SYNCHRONOUS COMBINED OPERATION**

When two or more pumps, each controlled by an inverter, are part of a pumping group, their start and stop can be managed in cascade, where the pumps start sequentially based on the water demand, or synchronously, where the working frequency of all pumps is synchronized. The latter mode allows for additional energy savings.

## 1 INVERTER + 1 OR 2 DOL PUMPS

A first method of splitting consists of installing one pump driven by the inverter and 1 or 2 DOL pumps directly connected to the main power (Direct On Line). Inverter switches the 1 or 2 DOL pumps on/off through contactors. Inverter alternates the two DOL pumps to average pump wear.

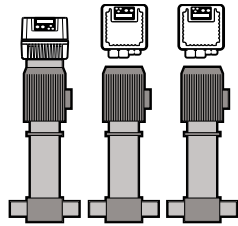

## FROM 1 TO 8 INVERTERS IN COMBO CONNECTION

A second way of splitting (named COMBO) consists of using several pumps in parallel (up to 8) each driven by an inverter. In this way, efficiency and the reliability of the pump group is maximised. Each device controls and protects its pump and the operation is shared among all the connected pumps to average pump wear. In case of failure the remaining pumps will maintain the pumping operation.

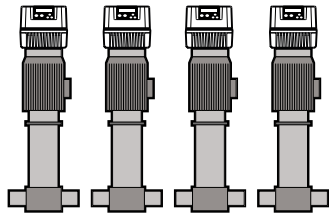

## FROM 1 TO 8 INVERTERS IN COMBO + 1 OR 2 DOL PUMPS

Lastly, it is possible to equip the system with multiple pumps in COMBO mode and an additional 1 or 2 DOL pumps, controlled and protected by PILOT, which come into operation to compensate for additional water demand.

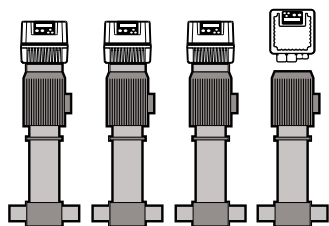

## UNMATCHED USER EXPERIENCE

Thanks to the Nastec NOW app it is possible to communicate with all Nastec SMART Bluetooth® devices in order to:

- Monitor multiple operating parameters simultaneously on the wide, high-definition colour screen of your smartphone or tablet.
- Develop programs, save them in the archive, copy them to other devices and share them among multiple users.
- Get energy consumption statistics and check the alarm log.
- Remotely control a Nastec device via Wi-Fi or GSM by tethering to a nearby smartphone.
- Create reports with the possibility of adding notes and images, and email or store them in the digital archive.



# VASCO - VARIable Speed COntroller, in addition to other control modes, performs the operation at constant differential pressure

by using a differential pressure sensor or using 2 pressure sensors installed in the suction and delivery sides of the pump.

Difference value is calculated by the inverter itself from the two values read.

This solution enables significant cost savings as well as providing protection against cavitation (by setting a minimum alarm pressure on the suction side) and against overpressure (by setting a maximum pressure alarm on the delivery side).

Constant differential pressure control can be extended to operation in a group, i.e. twin pump application.

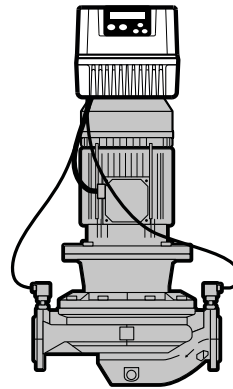

COMBO system ensures alternation of the pumps during operation to average the pumps' wear and easily plan maintenance operations.

In systems characterized by high drops in pressure, VASCO - VARIable Speed COntroller performs the proportional differential pressure control to maximise energy saving.

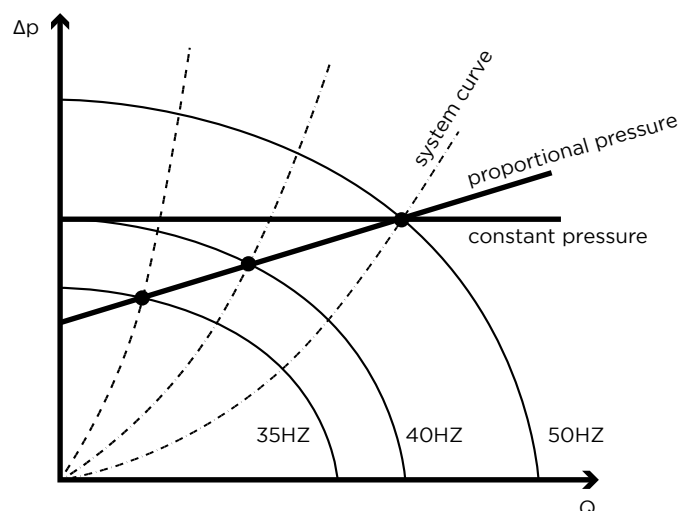

# SUBMERSIBLE PUMPS

By installing the inverter on the wall, it is possible to power submerged pumps of various power ratings. Sometimes, it is also necessary to insert special filters between the inverter and the pump to:

- reduce voltage spikes in the motor winding due to reflection phenomena (dV/dt filters)
- prevent electromagnetic interference in the surrounding environment (sinusoidal filters)

Upon request, Nastec offers a complete range of filters suitable for every need.

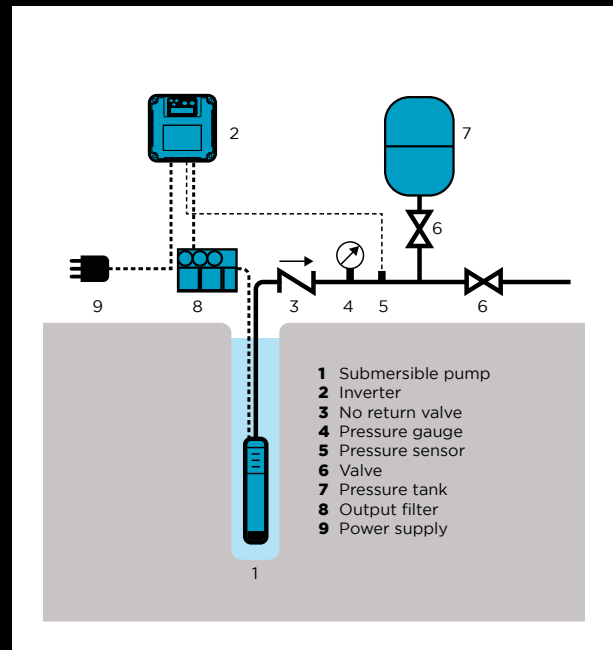

# TECHNICAL SPECIFICATIONS

Model	Vin ± 15%	Max V out	Max I out	P2 motor power*	Size
	VAC	VAC	A	kW	
V209	1 x 230	1 x Vin	9	1,1	1
		3 x Vin	7	1,5	1
V214	1 x 230	1 x Vin	9	1,1	1
		3 x Vin	11	3	1
V218	1 x 230	3 x Vin	18	4	2
V225	1 x 230	3 x Vin	25	5,5	2
V306	3 x 230	3 x Vin	6	1,1	1
V309	3 x 230	3 x Vin	9	2,2	1
V314	3 x 230	3 x Vin	14	3	2
V318	3 x 230	3 x Vin	18	4	2
V325	3 x 230	3 x Vin	25	5,5	2
V330	3 x 230	3 x Vin	30	7,5	2
V338	3 x 230	3 x Vin	38	9,3	3
V348	3 x 230	3 x Vin	48	11	3
V365	3 x 230	3 x Vin	65	15	3
V375	3 x 230	3 x Vin	75	18,5	3
V385	3 x 230	3 x Vin	85	22	3
V3118	3 x 230	3 x Vin	118	30	3
V3158	3 x 230	3 x Vin	158	37	4
V3185	3 x 230	3 x Vin	185	45	4
V3215	3 x 230	3 x Vin	215	55	4
V3268	3 x 230	3 x Vin	268	75	4
V406	3 x 380-460	3 x Vin	6	2,2	1
V409	3 x 380-460	3 x Vin	9	4	1
V414	3 x 380-460	3 x Vin	14	5,5	2
V418	3 x 380-460	3 x Vin	18	7,5	2
V425	3 x 380-460	3 x Vin	25	11	2
V430	3 x 380-460	3 x Vin	30	15	2
V438	3 x 380-460	3 x Vin	38	18,5	3
V448	3 x 380-460	3 x Vin	48	22	3
V465	3 x 380-460	3 x Vin	65	30	3
V475	3 x 380-460	3 x Vin	75	37	3
V485	3 x 380-460	3 x Vin	85	45	3
V4118	3 x 380-460	3 x Vin	118	55	3
V4158	3 x 380-460	3 x Vin	158	75	4
V4185	3 x 380-460	3 x Vin	185	90	4
V4215	3 x 380-460	3 x Vin	215	110	4
V4268	3 x 380-460	3 x Vin	268	132	4

\* Typical motor power. It is recommended to refer to the rated motor current when selecting the suitable model.

Nastec offers a wide range of accessories including pressure sensors, flow sensors, temperature sensors, shielded cables, input and output filters. For more information, contact our sales staff.

# GENERAL SPECIFICATIONS

- Rated frequency: 50 - 60 Hz (+/- 2%)
- EMC compliance: EN61800-3 C2
- Energy Efficiency Class (EN61800-9-2): IE2
- Relative humidity in the working environment: 5 - 95% non-condensing
- Operating ambient temperature: from -10 °C (14 °F) to 60 °C (140 °F)
- Maximum operating ambient temperature at full load: 40°C (104 °F)
- Maximum altitude at full load: 1000 m
- Vibration resistance (Sizes 1, 2): EN60068-2-6:2008, EN60068-2-27:2009, EN60068-2-64:2008
- Degree of protection:
  - IP66 (NEMA 4X) Taglie 1, 2
  - IP54 (NEMA 12) Taglie 3, 4
- Settable digital outputs N.O. or N.C.:
  1. Motor run signal
  2. Alarm signal
  3. DOL 1 pump
  4. DOL 2 pump
- Analog inputs (10 or 15 VDC):
  1. 4-20 mA
  2. 4-20 mA
  3. 4-20 mA o 0 - 10 VDC
  4. 4-20 mA o 0 - 10 VDC
- 4 digital inputs, configurable N.O. or N.C. for motor run/stop.
- RS485 MODBUS RTU, BACnet Bluetooth® SMART

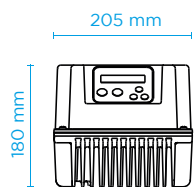

Size 1

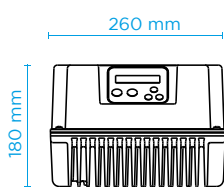

Size 2

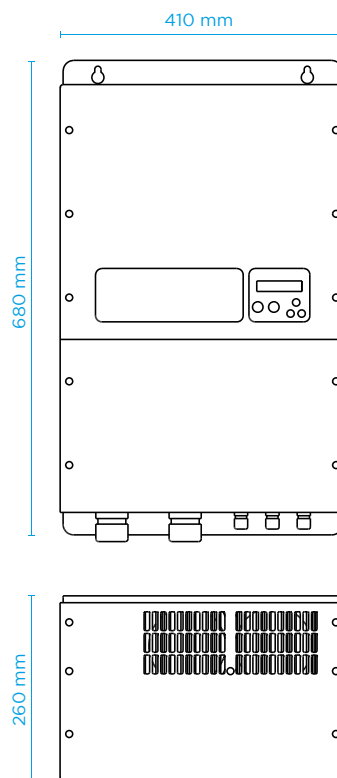
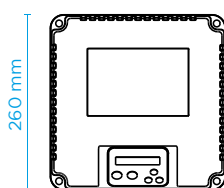
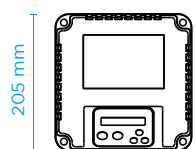

Size 3

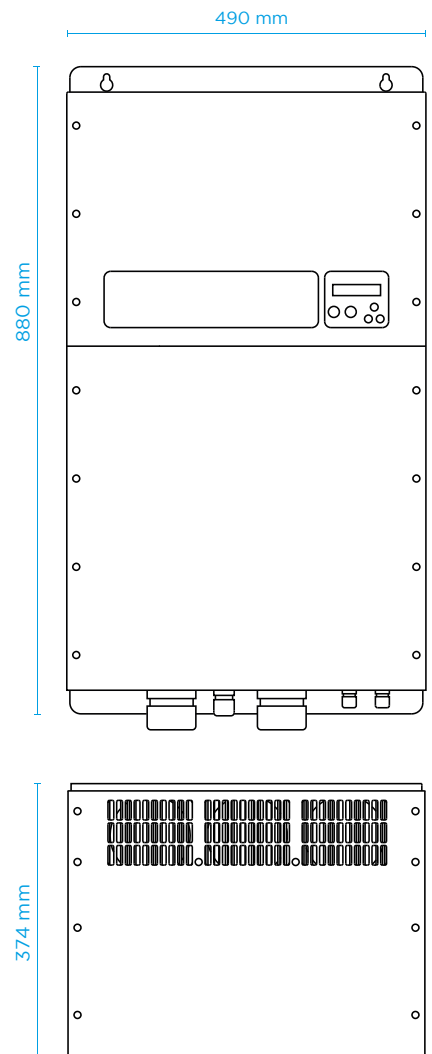

Size 4

# nastec.eu



*We were born in 2007 with over 30 years of previous experience in water pumps.*

*We develop products dedicated to specific applications. We don't claim to do everything, but we strive to do the best at what we do.*

*We pay attention to details.*

*We love manufacturing and encourage every form of repair. That's why we offer spare parts.*

*We update our products while maintaining compatibility with the past.*

*We support our customers always and by every possible means.*

*We are global in sales but local in assistance.*

*Our mission? To make pumping systems intelligent, efficient, and connected.*

**Nastec srl**

Via della Tecnica 8  
36048 Barbarano Mossano  
Vicenza - Italy

tel +39 0444 886289  
fax +39 0444 776099  
info@nastec.eu



> we move it faster >